

V2

15.0 DIRTcar Rules

ANY CAR, TEAM AND/OR DRIVER THAT DOES NOT MEET THESE SPECIFICATIONS AND/OR EQUIPMENT REQUIREMENTS WILL BE SUBJECT TO PENALTIES AS DETERMINED BY THE DIRTCAR OFFICIALS.

2017 DIRTcar Pro Late Model TO ALL COMPETITORS/PARTICIPANTS

- ❖ Under the guideline of the 2017 DIRTcar Pro Late Model rules any and/or rules and as stated in the 2017 DIRTcar Rule Book, all DIRTcar rules apply to all divisions. Local track rules pertaining to the racing procedures and/or overall rules that are administered by the local track officials and management may apply at local tracks in DIRTcar sanctioned events. Instances, where applicable, local track may be applied.
- ❖ The following are the 2017 DIRTcar Pro Late Model rules. All amendments supersede any previous rules regarding any technical article and/or aspect.
- ❖ Under the guideline of the 2017 DIRTcar Pro Late Model rules any and/or rules and as stated in the 2017 DIRTcar Rule Book, all DIRTcar rules apply to all sanctioned divisions.
- ❖ The specifications published shall be considered a section of the “*Official Rules and Specifications*” for all events, series and sanctions by World Racing Group. All sections should be considered when determining specifications and governance.

Table of Contents:

15.0	DIRTcar Pro Late Model Rules
15.1	Engines
15.2	Fuel, Fuel Cells and Fuel Systems
15.3	Muffler and Sound Reduction Devices
15.4	Traction Control Devices
15.5	Chassis/Frame
15.6	Weight
15.7	Body
15.8	Suspension
15.9	Roll Cage
15.10	Wheels
15.11	Tires
15.12	Safety
15.13	Other
15.14	Series Decal and Patches
16.0	Drawings

15.0 DIRTcar Pro Late Model Rules

ANY CAR, TEAM AND/OR DRIVER THAT DOES NOT MEET THESE SPECIFICATIONS AND/OR EQUIPMENT REQUIREMENTS WILL BE SUBJECT TO PENALTIES AS DETERMINED BY THE DIRTcar and/or World Racing Group OFFICIALS.

15.1 Engines

A.) The Chevrolet Performance Parts 602 engine (GM Part Number – 88958602) or the Chevrolet Performance Parts 604 crate engine (GM Part Number – 88958604) will be the only two engines permitted for competition. All engines are to remain sealed from the factory. The original factory seals must remain unaltered, tampering, removal, modifications of any type and/or broken factory seals will not be permitted. (The Chevrolet Performance Parts 602 and/or 604-crate engine may have part number changes from time-to-time as issued by the manufacturer.)

B.) All engines and all components must remain in their original configuration and form as purchased and/or delivered from the factory. Any changes will result in disqualification from the event. Any alterations to the engine will not be permitted.

C.) Any part that is sealed from the factory that has been tampered with and/or removed will result in an immediate penalty. The minimum penalty will be a \$1,000 fine, loss of all accumulated points for the year and a loss of all earned purse money for the event night.

D.) Any issued penalty may include and will not be limited to a suspension of the car, driver, car owner, engine builder from participation in any World Racing Group event.

E.) Any participant (driver, car owner and/or engine builder) that is found to have tampered with the engine will lose all points accumulated for the season, all earnings and the parts will be impounded for competitive analysis. In addition the participant may be suspended indefinitely from all World Racing Group events.

F.) Changes and/or alteration to the engine, intake manifold, cylinder heads, valve covers, valve components, front cover, oil pan, harmonic balancer and/or any parts on or in the engine will not be permitted.

ENGINE INSPECTION AND/OR ENGINE EXCHANGE

A.) World Racing Group and/or DIRTcar Officials reserve the right to exchange or impound any engine at any time for competitive analysis and for inspection. Failure to allow the engine to be retained for the impound procedure will result in disqualification from the event and possible further penalties.

B.) The engine that has been impounded and/or exchanged will retain all components as the engine was received from the factory or on the factory sale list.

CRATE ENGINE DISTRIBUTOR/IGNITION

A.) Magnetos will not be permitted.

B.) Electronic ignition will be permitted.

C.) MSD-type, ignition amplifier boxes will be permitted. The MSD 6ALN Ignition box is recommended.

D.) Series retains the right to change MSD boxes with any car at any time without notice.

CARBURETOR / CARBURETOR SPACER

A.) any maximum 750 CFM carburetor will be permitted. The carburetor must have a maximum 1-11/16"-inch base plate.

B.) A maximum one (1) inch spacer measured between the bottom of the base plate and the top of the intake manifold, including gaskets, will be permitted. The spacer must remain one (1) inch across the entire plain of the spacer.

C.) The spacer must not extend into the intake manifold.

D.) One gasket will be permitted from the carburetor the spacer. One gasket will be permitted from the bottom of the spacer to the top of the intake manifold.

E.) Gaskets must be standard for application. Gaskets that are exceed a standard OEM thickness for a carburetor/spacer-type application will not be permitted.

F.) The use of two (2) throttle return springs is recommended.

WET SUMP OILING SYSTEM

A.) Only the standard GM Wet Sump Oil Pump will be permitted. External oil pumps of any size or 'stage', even if considered a wet-sump single stage-type will not be permitted.

B.) One (1) remote type oil filter and external oil lines that transfer oil through the filter only will be permitted.

C.) One (1) oil cooler will be permitted.

15.2 – Transmission/Driveline and Driveline Components

A.) Direct drives systems of any-type will not be permitted.

B.) The transmission must be bolted to the engine it must have forward and working reverse gear(s) and must be able to shift to forward or reverse with engine running.

C.) All cars must be equipped with a working self-starter.

15.2.1 – Driveshaft

- A.) The driveshaft must be a minimum of 2"-inches in diameter. All drive shafts must be painted white.
- B.) Only one (1) drive shaft connected from the transmission to the center section of the rear end will be permitted.
- C.) A minimum of one (1) driveshaft hoop / sling must be fastened securely to the frame. It is recommended that two (2) driveshaft hoops / slings be used.

15.2.3 – Rear End

- A.) Any type of rear end differential / center section will be permitted.
- B.) Live-axle type rear ends will not be permitted.
- C.) Independent rear suspensions will not be permitted.
- D.) Floater-type wide-five hub assemblies will be the only hub assemblies permitted
- E.) **The axle housing must be of the "closed tube" design utilizing "full floating" magnetic steel axle shafts.**
- F.) **The center section of the axle housing must be manufactured of either aluminum or magnesium.**
- G.) **Axle tubes must be one (1) piece. Axle tubes must be manufactured of aluminum or magnetic mild steel. Axle tubes manufactured of exotic, heavy materials will not be permitted. The outside diameter of the axle tubes must not exceed three (3) inches. Axle tube internal inserts or external sleeves will not be permitted. The addition of any ballast weight to the axle housing will not be permitted.**
- H.) **Axle tube, including axle tube sleeves, donuts, or added parts may not exceed (3) three inches O.D. (outside diameter) at any point from center section to hub.**

15.3 Fuel, Fuel Cells and Fuel System

- A.) All cars must have fuel cells that meet and/or exceed FT3 specifications. The fuel cell must have a maximum capacity of 35 gallons.
- B.) The fuel cell must be enclosed completely in a container that is a minimum thickness of 20-gauge magnetic steel and/or .060"-inch aluminum.
- C.) The entire container must be visible for ease of inspection.
- D.) The fuel cell must be mounted behind the rear axle between the rear tires, a minimum of 4"-inches ahead of the rear bumper. The bottom of the fuel cell must not be any lower than the bottom of the rear end/quick change housing.
- E.) The fuel cell must be mounted with a minimum of two (2) .125"-inch thick steel straps. The straps must cover the entire cell. Fuel cells that are mounted in a square tubing frame will be permitted. A minimum of 7/6"-inch ASTM Grade 8 bolts must be used to mount the fuel cell to the frame.
- F.) The fuel pick up must be positioned on the top or right side of the fuel cell and be constructed of steel. The fuel pick up must have a check valve.
- G.) Only leaded and/or unleaded gasoline will be permitted for competition. Standard pump gasoline is recommended.
- H.) Only mechanical and/or belt driven fuel pumps will be permitted. Fuel injection system(s) and/or electrical fuel pumps and/or any type of pressurized fuel system will not be permitted.

15.4 Exhaust - Muffler and Sound Reduction Devices

- A.) The exhaust flow must be parallel to the ground. Exhaust systems that direct the flow toward the ground will not be permitted.
- B.) All exhaust systems/headers must end with a collector.
- C.) 'Tri-Y' headers will not be permitted.
- D.) Several tracks have a locally enforced decibel rule, which preempt any particular muffler rule. Some tracks may have a maximum sound level rule of 95 decibels at 100 feet. This rule will be

enforced by local government agencies. Such decibel rules preempt utilizing the required mufflers in sub-section 15.2.A.

15.5 Traction Control Devices

- A.) All electronic and/or computerized wheel spin and/or ignition retardation and/or acceleration limiting and/or traction control devices of any type will not be permitted.
- B.) Adjustable ping control devices, dial a chip controls, timing controls and/or automated throttle controls will not be permitted.
- C.) C.)Adjustable restrictor plates will not be permitted.
- D.) Remote control components of any-type will not be permitted.
- E.) Radios and/or devices for transmitting voice and/or data will not be permitted.
- F.) Data acquisition systems will not be permitted.

15.6 Chassis/Frame

- A.) The minimum wheel base minimum will be 103"-inches with a maximum wheel base of 105"-inches.
- B.) All frames must be fabricated from magnetic steel with a minimum of 2"-inches x 2"-inches or rectangle material with a minimum material thickness of .083"-inches.
- C.) A minimum of 1.75" Outside Diameter magnetic steel tubing, 4130 Chrome Moly or DOM with a minimum material thickness of .083"-inches, will be permitted for frames that are fabricated from round tubing.
- D.) Rear bumpers that are stubbed may only extend a maximum of 8"-inches beyond the frame. Any stubbed rear bumper that extends further than the maximum of 8"-inches must be formed and directed 8"-inches toward the front of the car.
- E.) External rub rails will not be permitted.
- F.) All cars must be equipped with a tow hook and/or strap for the purpose of towing.
- G.) All battery supports and/or mounts must be secure and braced in two (2) horizontal positions and one (1) vertical position.
- H.) Any frame built on or after January 1st, 2006, must have the builder's unique serial number plate prominently attached to the left side roll cage upright. The plate must be welded in place. All characters on the plate must be a minimum of ½"-inch in height and the serial number must not exceed 8 characters.

15.7 Weight / Ballast

- A.) The total weight of the car with the driver will be:
 - 1.) A minimum of 2,300 lbs as weighed on the track scales for a car with a '602' Chevrolet Performance Engine.
 - 2.) A minimum of 2,400 lbs as weighed on the track scales for a car with a '604' Chevrolet Performance Engine.
- B.) Weights up to 50 lbs must be positively fastened by 2 ½"-inch, minimum grade 5 bolts with a minimum of two (2) weight clamps. Threaded rods will not be permitted. All weights must be painted white and clearly labeled with the car number on it.
- C.) **All added weight(s) must be securely attached to the frame below the body decking.**
- D.) **Frame is defined as the steel welded structure only.**
- E.) **Any part that moves or is not a fixed component to the steel frame structure may not be used for any weight attachment.**
- F.) Any car that loses any weight/ballast during an event may be subject to a penalty.
- G.) Weights attached to the rear bumper and/or outside the frame will not be permitted.
- H.) Pellet-type and/or liquid-type weight/ballast will not be permitted.

- I.) Driver operated weight adjustment, 'weight jacking' devices will not be permitted.
- J.) **The scales used for the event, provided by the series or the track will be considered the official scales for the event.**
- K.) **Scales will be available for any team to verify its car weight and determine the scale weight.**
- L.) **Officials will allow a car to re-scale two times by pulling off scale and pulling back on. Reading of the third attempt will become the entered weight.**

15.8 Brakes, Brake Components, Wheel Hub:

- A.) Brake calipers must be manufactured of aluminum.
- B.) The brake caliper including brake caliper pistons must be used as produced by the brake caliper manufacturer.
- C.) **Brake rotors must be manufactured of magnetic or stainless steel.**
- D.) Brake rotors must be used as produced by the brake rotor manufacturer.
- E.) Wheel hubs must be manufactured of **aluminum or magnesium.**
- F.) Wheel hubs must be used as produced by the wheel hub manufacturer.
- G.) **The combined weight of the wheel hub, wheel bearings and seal, spindle nut and washers, brake rotor and attaching hardware, the axle cap, and the wheel spacer must not exceed 27 pounds.**

15.9 Body

(Refer to diagrams 1 - 4 attached)

15.9.1 – Overall Appearance

- A.) The car must be neat in appearance and must display the car number of the front nose and the rear fuel cell. The minimum height for the number will be 6"-inches.
- B.) The car must have legible numbers on each side and on the roof a minimum of 18"-inches high,
- C.) The driver's last name must be placed in legible letters on both doors or the rocker panels and across the front of the roof in letters that are a minimum of 8"-inches in height.

15.9.2 - General Body

- A.) The nosepiece is not required to match the body style of the make and manufacturer of the car.
- B.) All cars must have a minimum half-inch (1/2") and a maximum of one (1) -inch radius at the top of fenders, doors and quarter panels. Sharp edge(s) will not be permitted.
- C.) The floorboards and firewall must completely cover the driver's area with no openings.
- D.) Fins and/or lips of any-type will not be permitted anywhere along the entire length of the car.
- E.) The bodyline must be a smooth even line from front to rear.
- F.) Wedge shape cars and/or body styles will not be permitted.
- G.) "Belly pans" or any type of enclosure on the bottom of the car will not be permitted. A maximum 1/8"-inch skid plate to protect the oil pan is permitted.
- H.) Wings and/or tunnels and/or any type of air deflection device will not be permitted underneath the body and/or chassis of the car.
- I.) A maximum of one (1) stone deflector, for rear mounted oil pumps, oil filters, and for the main oil tank will be permitted. The deflector may be made of steel, aluminum, or heavy gauge wire. The cover may only be mounted near the unit it is designed to protect with a maximum size of 18" x18" and only mounted from the upper right frame rail to the lower right frame rail.
- J.) Panels of any type under the rear deck running from the front to the rear of the car will not be permitted.
- K.) Bodies that are non-approved will be assessed a fifty pound weight penalty.

- L.) Any style air cleaner scoop used must be positioned in front of/around the air cleaner and must not exceed 1"-inch in height above any part of the air cleaner. Any type of flange and/or air deflection device and/or fin that is designed to direct airflow will not be permitted.
- M.) Cockpit adjustable components with the exception of brake bias adjusters will not be permitted. Adjusters of any-type, including but not limited to adjustable shocks, hydraulic or pneumatic weight jacks, trackers, ignition boxes or similar adjustable components will not be permitted inside the cockpit of the car or within reach of the seated driver.
- N.) **The top edge, measured from the ground, of the rear quarter, door and front fender to the point where the fender flare attaches must be a straight line, within one inch on both sides of the car.**

15.9.3 – Nosepiece

- A.) Only approved nosepieces will be permitted. A list of approved manufactures and part numbers for competition in World of Outlaw Late Model and UMP DIRTcar competition follows:
 1. Dominator –
 2. MD3 – Performance Bodies
 3. ARP Air Speed nose
 4. Five-Star MD3 type
 5. Performance Bodies/Five Star MD3 2015
 6. **Performance Bodies/ Five Star 2016 Evolution**
- B.) Approved nose assemblies must be installed per the manufactures instructions. All nose assemblies must meet the maximum/minimum dimensions, shall maintain manufacture appearance and not be altered.
- C.) Front nose assemblies, not meeting the maximum/minimum dimensions, at the series discretion, may be permitted to compete as a "non conforming" nose with a minimum of 50 additional pounds mounted in front of the motor plate. At series discretion, degree on non-compliance may require additional weight and/or placement of penalty weight in front of radiator.
- D.) All nosepieces must be made of molded type material.
- E.) **Nose filler panel shall be flat across entire surface, dishing or raising prohibited**
- F.) Two-piece noses must be positively fastened together in the center. Spacers added to gain width will not be permitted.
- G.) The nosepiece must be mounted in a manner that does not alter its original shape.
- H.) The nose shall remain flat above the nose lip/wicker bill. Alterations and/or additions may be made to this area other than cooling holes will not be permitted.
- I.) The nosepiece can extend a maximum of fifty-two inches (52") from the center of the front hub to the farthest point extending forward.
- J.) The nosepiece must display a headlight decal package. A one-race grace period, running contrasting color tape in the shape of a headlight will be permitted.
- K.) **A maximum of three two inch holes may be drilled into the nose for the sole purpose of air flow for engine cooling purposes. No ducts of any type will be allowed.**

15.9.4 - Roof

- A.) The roof length from front-to-back must be a minimum of 44"-inches with a maximum of 54" inches.
- B.) The roof width from side-to-side must be a minimum of 48"-inches to a maximum of 52"-inches.
- C.) The must be stock appearing and be mounted level.
- D.) The minimum height of the roof will be 45"-inches with a maximum height of 48"-inches.
- E.) The roof must be mounted parallel to the body and near the center of the car as viewed from the front of the car.
- F.) A maximum 1-1/2" roll, turned downward will be permitted along the front of edge of the roof. A maximum 1"-inch roll, turned downward, will be permitted along the rear edge of the roof. These

modifications will be permitted to improve the strength of the roof. Any other modifications to the roof will not be permitted.

- G.) Flat and/or odd shaped roofs will not be permitted. Bellied and hollowed roofs will not be permitted. 4.3.8. Any sun/antiglare shields may not exceed a 4" drop from the top roof line, and must hinge for easy exiting.
- H.) A maximum of two (2) roof edge bead rolls of a maximum height of ½"-inch the length of the roof will be permitted.
- I.) The roof posts and spoiler support(s) may not overlap.
- J.) Only single plated roofs will be permitted.
- K.) The maximum thickness of the roof at any point will be ½"-inch.
- I.) The roll cage and associated frame members above the interior panels (decking) must remain open. Enclosures will not be permitted.

15.9.5 Roof Supports and Window Side Panels

- A.) All roof side panels must extend to the edge of the body.
- B.) The roof side panel window size must be a minimum of 10"-inches x 15"-inches and must match drawing number -2- side view.
- C.) The side window area may be covered with clear Lexan and/or equivalent type material, be cut out and/or represented by a decal. Both roof support opening must be covered and/or both must be left open.
- D.) The left and right side window panels must match.
- E.) A maximum bow of 2"-inches outward on the window side panels as viewed from behind will be permitted.
- F.) The front roof supports up to 2"-inches in width must extend forward to the rear of the hood.

15.9.6 Front Fenders, Fender Flares and Hood

- A.) The hood and the front fenders must be level and flat from the left to the right side of the car.
- B.) The outside edges of the hood and/or the fender must remain inside the overall bodyline.
- C.) The front fender may be a maximum of 37"-inches in height, measured vertically from the ground to the top of the fender behind the front tires.
- D.) The front fender flares must be made of plastic and must not alter the original shape of the nose piece.
- E.) The front fender flares must not extend beyond the front tires more than 1"-inch per side to a maximum width, edge-to-edge, of 90"-inches in width with the wheels pointed straight.
- F.) The front fender flares must be flat across the entire width of the car. **Front fender flairs shall not extend, bubble or rise more than a maximum of four inches (4") at any point of the front fenders and/or hood.**
- G.) The front fender flares must have collapsible supports.

15.9.7 Doors

- A.) The door-to-door measurement must not exceed 76"-inches in width at the top of the doors.
- B.) The door-to-door measurement must not exceed 82"-inches in width when measured at the bottom of the doors in the center of the car.
- C.) The doors must not exceed 37"-inches in height when measured from the ground to the top of the door. **The measurement from the ground to the top of the door, on both sides of the car – right door and left door, must measure within one inch (1") variance.**
- D.) The door sides may not break inward from the top 76"-inches and bottom 82"-inch measurements. Hollow and/or belled doors will not be permitted.
- E.) The minimum ground clearance will be 3"-inches.

15.9.8 Quarter Panels

- A.) The maximum distance from the center of the rear hub to the top quarter of the panel is 53"-inches.
- B.) The quarter panels must not exceed 76"-inches in width at any point as measured at the top of the panels.
- C.) The rear deck must taper in a symmetrical manner from the center of the rear hub to the rear spoiler with a minimum height of 72"-inches and a maximum height of 76"-inches.
- D.) The maximum width for the quarter panels measured from outside-to-outside measured 19"-inches from the ground and/or at the bottom of the quarter panel will be 86"-inches.
- E.) Any breaks and/or bends formed in the sides of the quarter panel that move the panel toward the center of the car will not be permitted. Hollow and/or bellied panels will not be permitted.
- F.) The maximum distance from the center of the rear hub to the rear trailing edge of the quarter panel will be 48"-inches.
- G.) G.) The maximum height from the ground to the top of the rear deck at the top of the rear quarter panel is 38"-inches.
- H.) A minimum of 2"-inches of tire clearance between the tire and the body will be required.
- I.) Skirting that extends behind the rear quarter panel will not be permitted.

15.9.9 Spoilers and Spoiler Braces/Supports

- A.) Only aluminum and/or Lexan and/or Lexan-type rear spoilers will be permitted.
- B.) The maximum overall height of the rear spoiler will be 8"-inches. The maximum width of the rear spoiler, including braces and/or supports is 72"-inches.
- C.) The rear spoiler must begin at the deck and extend 8"-inches from that point. Suspending the spoiler to create a wing-type device will not be permitted.
- D.) The rear spoiler must begin at the rear most point of the quarter panels.
- E.) Only three spoiler braces/supports will be permitted. The front edge of the spoiler brace/support must be in line with the spoiler.
- F.) The outside spoiler supports must not be mounted any-wider that the top of the quarter panel(s) and must be centered on the rear deck.
- G.) In the event that aluminum angle is used to bracer the upper edge of the spoiler, the angle must not add to the height and/or length of the spoiler in any way.

15.9.10 Interior

- A.) The interior of the cockpit must be a minimum of 11"-inches below the top of the roof and/or roll cage, measured perpendicular to the ground from the bottom of the roof to the cockpit deck. Roof rolls are not part of the measurement.
- B.) The side window opening(s) must be 15"-inches from the top of the door to the bottom of the roof.
- C.) Supports bars that block the right window from the driver exiting the cockpit will not be permitted.
- D.) A single rock guard (Lexan screen) tapered back from the steering wheel to the height of 1"-inch in line with the driver's chest providing the 11"-inch minimum clearance is met at any point from the roll cage to the body and/or rock guard.
- E.) If the interior deck drops the drop must begin at the rear of the engine plate with a maximum of 4"-inches and must not drop below 4"-inches rear of the hood. The start of the dropped interior must remain closed as a part of the fire wall. The entire width must be closed off with sheet metal.
- F.) The interior must gradually taper up to the quarter panel height and must be level for a minimum of 20" inches from the rear of the quarter panel and deck.

15.9.11 Driver Compartment

- A.) A full metal firewall fabricated from magnetic steel and/or aluminum must encompass the driver's compartment from front-to-rear, on both sides and floor boards. The firewall must be completely enclosed.

- B.) The driver's seat must be a high back aluminum seat, designed specifically for racing, located on the left side of the car and mounted per the manufacturer's instructions securely to the frame.
- C.) The seat design should be one from a current manufacturer and/or recommended to include the full containment design. Installation of the full containment seat should follow the manufacturer's instructions.
- D.) All cars must be equipped with a quick-release type steering wheel.
- E.) The driver compartment must have a starting switch and/or button within reach of the driver.
- F.) A clearly labeled electrical on/off 'kill' switch must be within reach of the driver.
- G.) Mirrors of any-type will not be permitted.
- H.) Radios and/or electronic and/or data communication devices will not be permitted.
- I.) Any edge and/or sheet metal end in and around the driver compartment must be protected with trim and/or beading and rounded. Sharp and protruding edges will not be permitted.
- J.) A substantial rock guard with a minimum of three (3) additional roll bars must be mounted in front of the driver. The rock guard must be made from wire screen. Windshield screens must be a minimum of .090-inches and must be securely fastened.
- K.) A fully charged fire extinguisher meeting SFI 167.1 specifications with an activation push and/or pull knob within reach of the driver is required.

15.10 Rear Suspension & Suspension Components

A.) General

- 1) Rear suspension designs and applications are constantly evolving. Although the intent of the rear suspension rules are an attempt to accommodate the majority of suspension and suspension component designs and applications currently being used in competition, the rules cannot be absolute. Any and all new designs or modifications to an existing suspension and/or suspension component must be communicated to and approved by the Series Director before being used in competition.
- 2) Rear suspension must utilize either coil or leaf springs.
- 3) Rear suspension configuration used on current and new chassis(s) must be the design commonly known as four (4) link. Older cars currently competing with other rear suspension designs will be allowed to compete until further notification at the discretion of the Series Director.

B.) Axle Housing, Rear Differential

- 1) **The axle housing must be of the "closed tube" design utilizing "full floating" magnetic steel axle shafts.**
- 2) **The center section of the axle housing must be manufactured of either aluminum or magnesium.**
- 3) **Axle tubes must be one (1) piece. Axle tubes must be manufactured of aluminum or magnetic mild steel. Axle tubes manufactured of exotic, heavy materials will not be permitted. The outside diameter of the axle tubes must not exceed three (3) inches. Axle tube internal inserts or external sleeves will not be permitted. The addition of any ballast weight to the axle housing will not be permitted.**
- 4) **Axle tube, including axle tube sleeves, donuts, or added parts may not exceed (3) three inches O.D. (outside diameter) at any point from center section to hub.**

C.) Rear Suspension Frame Mounts

- 1) The frame/roll cage structure must have integral welded mounting brackets for the attachment of rear suspension components. Frame suspension mounts may be welded or bolted securely (without any movement) to the frame/roll cage structure.
- 2) The only materials used to fabricate frame suspension mounts that will be permitted are magnetic steel or aluminum.

- 3) Frame suspension mounts may be either a single or double shear configuration for mounting suspension components.
- 4) Single shear frame suspension mounts must be a minimum of 1/4 inch in thickness. Double shear frame suspension mounts must be a minimum of 3/16-inch thickness on both sides of the mount.
- 5) All frame suspension mount component mounting holes must be round and sized correctly for the fastener being used. Clearance between the fastener and the mounting hole must not exceed the next fractional drill size. Example: 1/2-inch fastener, 33/64 inch mounting hole.

D.) Axle Housing Mounts

- 1) Only one (1) axle-housing mount per side will be permitted.
- 2) **The only materials used to fabricate axle housing mounts (birdcages) that will be permitted is aluminum or magnetic mild steel. Axle housing mounts fabricated of exotic, heavy materials will not be permitted.**
- 3) **When fabricating axle housing mounts detail must be paid to functionality. The completed axle housing mounts, when comparing the right and the left side, must be as similar in design as possible.**
- 4) Axle housing mounts may be a solid (welded) type or a floating type (birdcage) design.
- 5) The final assembled axle-housing mount must be a one (1)-piece mount. When a floating type mount (birdcage) is fabricated using two (2) pieces, the two (2) pieces must create a common one (1)-piece pivot (barrel). The two (2) pieces must be fastened or welded together to prevent independent movement of the two (2) pieces. The axle-housing mount must attach directly to the axle tube with clearance only to permit rotation of the entire mount. Fore, aft or vertical movement of the mount or the axle housing within the mount will not be permitted.
- 6) The only materials used to fabricate axle-housing mounts that will be permitted are magnetic steel or aluminum.
- 7) Mounts for suspension attaching (radius) rods must be an integral part of the axle-housing mount. The mounts may be either a single or double shear configuration. When using a single shear configuration, a minimum thickness of 1/4 inch for magnetic steel or 1/2 inch for aluminum is required. When using a double shear configuration, a minimum thickness of 3/16 inch for magnetic steel or 1/4 inch for aluminum is required. Dynamic movement of any mount other than a rotational and pivoting movement as a result of suspension travel will not be permitted.
- 8) Unless otherwise authorized by the Series Director, the mounting of any component(s) other than suspension attaching (radius) rods or shocks will not be permitted on the axle housing mounts.

E.) Rear Suspension Attaching (Radius) Rods

- 1) A maximum of two (2) attaching (radius) rods per side will be permitted.
- 2) The only materials used to fabricate attaching (radius) rods that will be permitted are magnetic steel or aluminum
- 3) Attaching (radius) rods may be solid or tubular material. The material may be round or hexagon in shape.
- 4) Spherical rod ends or steel clevises must be used at the end of each rod for pivoting, static length adjustment, and mounting. Bushings of any type will not be permitted.
- 5) The final assembled attaching (radius) rod must not have the capability to change length dynamically by any means or devices.
- 6) Spherical rod end sizes may be a minimum of a 5/8-inch rod end body with a 1/2 inch bearing to a maximum of a 3/4 inch rod end body with a 3/4 inch bearing.
- 7) In all applications, the correct size fastener must be used when mounting the spherical rod end to a bracket (example: 1/2 inch fastener must be used with a 1/2 inch bearing and mounting hole). Metal step spacers will be permitted to reduce the hole size of the spherical rod end bearing.

- 8) Attaching (radius) rods must mount directly to the frame suspension mount at the forward end and to the axle-housing mount at the rearward end.
- 9) All rear suspension fasteners must be magnetic steel with a minimum diameter of 1/2 inch. The use of grade 8 fasteners is highly recommended. All fasteners must be correctly sized for the component and application of use.
- 10) When rear suspension assembly is completed, the attaching (radius) rods must have a minimum of eight (8) inches between the pivots at both the frame suspension mount and the rear axle-housing mount.

F.) Rear Droop Limiter

- 1) One (1) droop-limited chain per side will be permitted.
- 2) The droop limiting chain may incorporate bump stops and/or springs.
- 3) The droop limiting chain must attach to a collar or bearing type mount on the rear axle tube and to the frame assembly directly above the lower mount. Chains to the rear axle mount (birdcage) will not be permitted.
- 4) Droop limiting chains must be mounted so that when taut they are as close to vertical as possible.

G.) Torque Control Devices

- 1) Lift arm assemblies and pull bars will be permitted.
- 2) Only one (1) torque control device may be used.
- 3) Lift arms must attach to the axle housing using a mounting configuration that prevents any movement between the lift arm and the rear axle housing. A gusset or brace bar to prohibit side-to-side flex will be permitted.
- 4) The forward end of the lift arm may use a spring over shock assembly (5th coil), a spring or bushing, and a limiting chain.
- 5) Pull bars may be adjustable on both ends; however, the adjustments must remain fixed during competition. Adjustors within reach of the driver will not be permitted.

H.) Rear Springs

- 1) Coil springs or leaf springs will be permitted.
- 2) Coil springs must be manufactured from magnetic steel. Leaf springs must be manufactured from either magnetic steel or approved composite material.
- 3) **Spring preload adjustments for coil springs must be made using mechanical adjusting nuts on the shock body.**
- 4) **Spring preload adjustments for leaf springs must be made using a mechanical adjusting device such as an adjustable shackle or threaded rod type mount.**
- 5) **Other than spring dampening by the shock absorber, hydraulic, pneumatic, or electrically controlled adjusting devices, (static or dynamic) that affect spring preload or race car heights will not be permitted.**

15.10.1 Shock Absorbers

- A.) For the 2017 season DIRTcar will impose a \$200.00 per shock claim and exchange if not a labeled "APPROVED" shock.
 - a. Promoter, Driver or DIRTcar Official has the right to claim any shock absorber. If the claim is refused all points and earned money from that event will be forfeited. Additional penalties may be assessed.
 - b. Only 2017 DIRTcar members in good standing may be eligible to present a claim.
 - c. To be eligible to place a claim any competitor must also finish within the top five positions in the event to be eligible to present a claim.

Track Rule (please check with your track for this requirement: DIRTcar Approved 'A' and 'B' shock absorbers are eligible for competition.

All shock absorbers must display the *DIRTcar approved decal* and/or DIRTcar approved marking on the body of shock absorber to be permitted to compete.

- B.) Shocks are intended to dampen and help control spring frequencies in both the compression and rebound motions. The amount of force applied to move the shock piston and shaft assembly may be varied with the option of shock "builds" however the piston and shaft assembly must have the ability to move in both directions.
- C.) Mono-tube, single piston, nitrogen gas charged shocks will be permitted. All shocks must utilize mechanical oil controls, such as: spring shim(s), drum and disc(s), check ball and spring, needle and seat for internal and external shock adjustments. Magnetic and/or electro-magnetic controls are not permitted.
- D.) Remote reservoirs/Canister shocks are NOT permitted.
- E.) Shock adjustments while the vehicle is in motion will not be permitted.
- F.) Shocks and shock components may only be manufactured from steel or aluminum.
- G.) Rotating parts will not be permitted inside or mounted to the shock absorber. Inertia/gyro style shocks are not permitted.
- H.) Thru-rod shocks will not be permitted.
- I.) Unless otherwise authorized, all shocks must be mounted as close to vertical as possible.
- J.) Approved shock locations are as follows:
- K.) One (1) shock will be permitted at each front wheel
- L.) One (1) shock will be permitted at the right rear wheel
- M.) Two (2) shocks will be permitted at the left rear wheel. When using only one (1) shock at the left rear wheel, the shock must be mounted behind the rear axle tube. When two (2) shocks are used at the left rear wheel, one (1) shock must be mounted behind the rear axle tube and the second shock must be mounted on top of or forward of the rear axle tube.
- N.) One (1) shock will be permitted mid-ship at the front of the lift arm assembly.
- O.) One (1) braking shock will be permitted. The shock must be mounted within three (3) inches of the center line of the rear axle center section. This shock must be mounted horizontally.
- P.) *Prior to introduction into competition a new design shock absorber must be submitted to World Racing Group / World of Outlaws Officials for approval. Shock absorber manufacturers may be required to provide a board of components for inspection and display.*

15.10.2 Suspension Components/Springs

- A.) Coil springs must be magnetic steel.
- B.) Leaf springs may be composite material or magnetic steel.

15.10.3 Steering Components

- A.) Only one power steering pump allowed

15.11 Roll Cage

- A.) All cars must have a roll cage fabricated from a minimum of 1-1/2" outside diameter with .065"-inch thick seamless magnetic steel tubing.
- B.) The side roll bars and/or door bars must extend into the door panels.
- C.) A minimum of three (3) bars must be utilized on the left side of the car in the door area.
- D.) Any of the bars that are utilized for the top portion of the roll cage, including, but not limited to the front and rear hoops, the top hoop and the uprights, must extend a minimum of 1"-inch above the driver's helmet.

- E.) All new frames and/or roll cages built on or after January 1st, 2006 an additional vertical side brace is required on the left side in vertical alignment with the steering wheel.

15.12 Wheels

- A.) Only steel or aluminum wheels will be permitted for competition.
- B.) The wheels must be mounted to the hubs utilizing lug nuts. "Knock off" and/or single type wheel mounting systems will not be permitted.
- C.) The maximum wheel width that will be permitted is 14"-inches.
- D.) The maximum front track width will be 90"-inches and the maximum rear track width will be 88"-inches, measured from the outside edge of the tire to the outside edge of the tire.
- E.) **The combined weight of the wheel, wheel hardware, wheel disc and fasteners, and tire must not exceed 40 pounds*. *The maximum combined weight in this rule is based upon current tire rules and may need to be adjusted in the event of an alternate tire.**
- F.) The maximum front track width will be 90"-inches and the maximum rear track width will be 88"-inches, measured from the outside edge of the tire to the outside edge of the tire.
- G.) **Only approved wheel discs will be permitted. Approved wheel discs are wheel discs that are fastened to the wheel using a minimum of three (3), 1/4 or 5/16 inch diameter magnetic steel hex head bolts. The use of wheel discs with any other type of fastener will not be permitted.**
- H.) **Approved fastening (nut assembly) systems:**
- **Keyser Manufacturing, part #100 7-101.**
 - **Wehrs Man. Part # WM377A-312 Aluminum 5/16 / WM377S-312 Steel 5/16**
 - **Triple X Chassis Part # SC-WH-7810(1" spring) / SC-WH-7820(1 3/8" spring)**
 - **Pit Stop USA Part #:**
 - **Smith Precision Products Part # MC-516-18**
- I.) **Only aluminum wheel spacers will be permitted** provided the track width(s) do not exceed their maximum dimensions

15.13 Tires

- A.) Only the Hoosier LM40 tires will be permitted for competition.
- B.) The maximum size for any tire in competition is 11"-inches x 29"-inches x 15"-inches, unless otherwise specified in written form to all competitors.
- C.) The maximum outside circumference of the tire will be 93"-inches, unless otherwise specified in written form to all competitors.
- D.) The maximum width of the tires measured from the outside edge(s) of the sidewalls across the face of the tire will be 16 3/4"-inches. There will be a tire hoop used for inspection and the tire must pass through the tire hoop freely, without any manipulation or outside contact.
- E.) The tire rule for any event may be amended in written form, to all competitors per any technical bulletin.
- F.) Chemical alterations, vulcanizing, tire softening, defacing and/or altering the face of the tire lettering and/or tire stamping will not be permitted.
- J.) Only approved tires will be permitted for use in competition.

15.14 Personal Safety Equipment – see section 3.0

15.12.1 General

Each competitor is the solely responsible of for the effectiveness and proper installation, per the manufacturer's specifications, of personal safety equipment and determining it to be adequate for competition at every event. Each competitor is expected to investigate and educate themselves for continuing improvement regarding their own personal safety equipment.

15.12.6 Other RECOMMENDED

- A.) Sharp and/or protruding edges in and around the cockpit will not be permitted.

- B.) Windshield screens should be a minimum thickness of 0.090 inch and should be securely fastened to the roll cage.
- C.) C.) A clearly marked electrical engine shut off switch within the reach of the driver.
- D.) A clearly marked fuel shut off valve within reach of the driver.
- E.) Only SFI flame retardant seat, roll bar, knee and steering pads and/or padding should be utilized.
- F.) Driveline U-Joint scatter shields are recommended.

15.16 Fire Suppression

- A.) **All racecars must be equipped with a thermally deployed automatic fire suppression system. The fire suppression system will consist of a DOT approved cylinder manufactured from aluminum or steel with a capacity of ten (10) lbs. of fire extinguishing agent, steel or steel reinforced lines, and two (2) thermally activated discharge nozzles.**
- B.) **All systems must meet or exceed SFI 17.1 specifications.**
- C.) **Systems must be fully charged with ten (10) lbs. of Dupont FE-36 or 3M NOVEC 1230 and display a legible and valid SFI and manufacturer label depicting fire extinguishing agent, capacity, and certification date. Cylinders that or beyond useful certification date must be inspected, serviced and re-labeled by the manufacturer.**
- D.) **Cylinders must be mounted forward of the fuel cell. Cylinders must be securely mounted to the frame/roll cage assembly. The certification label must be unobstructed and easily accessible for inspection when the mounting is complete.**
- E.) **The cylinder must be connected to the nozzles with steel or steel reinforced lines.**
- F.) **Two (2) thermally activated nozzles must be used. One (1) nozzle must be located directly above the fuel cell in the fuel cell area and the second nozzle located in the driver cockpit area.**
- G.) **An optional manual override cable may be used.**

15.13 Other

- A.) Cars will not be permitted to make a qualifying attempt without passing technical inspection
- B.) All cars may be subject to technical inspection at any time.
- C.) Full or partial car covers will be permitted only when there is inclement weather and/or the car is in its designated pit stall. All covers shall be removed prior to the car leaving its designated pit stall.
- D.) SFI-approved and labeled seat, roll bar, knee and steering pads and/or padding is recommended.
- E.) It is recommended that all teams have a fire extinguisher in the rear of their transporter. The fire extinguisher is recommended to be a minimum of 2.5 gallons FFF type chemical and/or equivalent.
- F.) F.). Two-way radios, crew-member to driver and/or any other means of electronic communication, other than the one-way radio required by the Series or track, will not be permitted.

15.14 Series Decal and Patches

- A.) All participants will be required to display decals as provided prior to entering into competition. If any required decal is not displayed loss of any awarded money will be the penalty.
- B.) Contingency and sponsorship awards, any team participating must meet the requirements of the award(s) such as decals, patches, product use and verification. There will be a written deadline presented to the teams for each element to be in place for the award requirements.

16.0 Drawings

- A.) – 1 – Top View
- B.) – 2 – Side View
- C.) – 3 – Spoiler Support
- D.) – 4 – Rear Roof Support

- 1.2e - Stock Nosepiece can extend a maximum of fifty-two inches (52") from center of front hub to farthest point extending forward.
- 1.3d - Roof height must be between forty-five (45") and forty-eight inches (48") from the ground.
- 1.5d - Front fenders can not exceed thirty-seven inches (37") in height measured from the ground.
- 1.5g - The front fender flares may not be higher than fenders by more than two inches (2").
- 1.6c - Doors can not exceed thirty-seven inches (37") in height measured from the ground.
- 1.7a - Fifty-two inches (52") maximum center of rear hub to top corner of quarter panel.
- 1.7f - Forty-eight inches (48") maximum length from center of rear hub to end of quarter panel.
- 1.7g - Thirty-eight inches (38") maximum height from top of deck to ground.
- 1.7h - Minimum of two inches (2") tire clearance from body.
- 1.7i - Any skirting can not extend beyond the quarter panel.

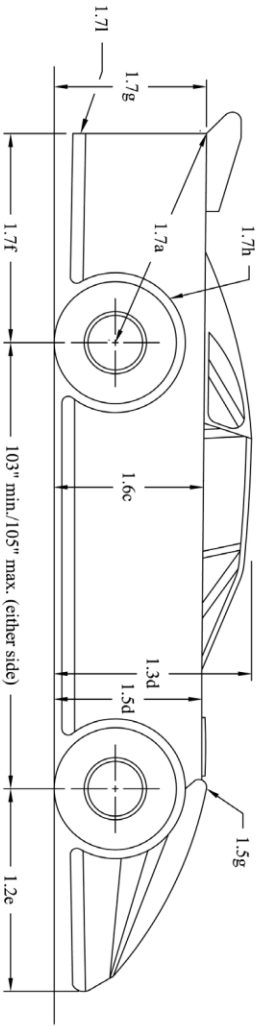

LATE MODEL
SIDE VIEW DIMENSIONS

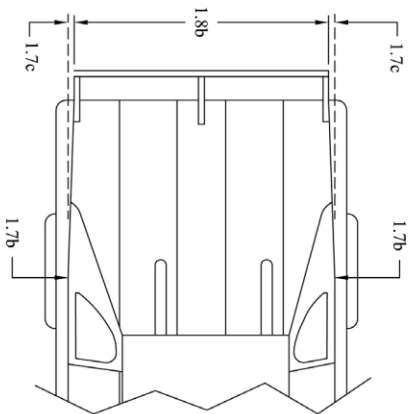

Option 1

Rear decks must taper from seventy-six inches (76"), as measured at the top over the rear hubs, uniformly back to seventy-two inches (72)" at the spoiler, equally on both sides.

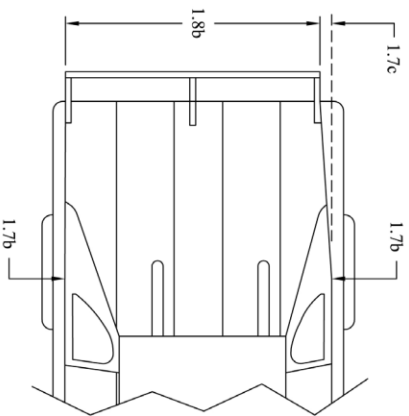

Option 2

Rear decks must taper from seventy-six inches (76"), as measured at the top over the rear hubs, uniformly back to seventy-two inches (72)" at the spoiler, on the left side only.

LATE MODEL REAR
QUARTER PANEL OPTIONS

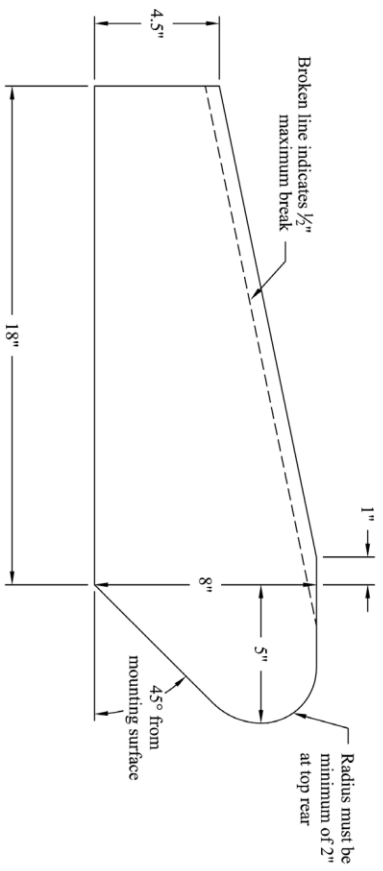

No more than three (3) spoiler supports permitted. Front edge of supports must be in line.

Dimensions Have Zero Tolerance

DIRT LATE MODEL
SPOILER SUPPORTS

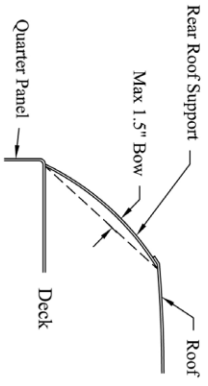

REAR VIEW

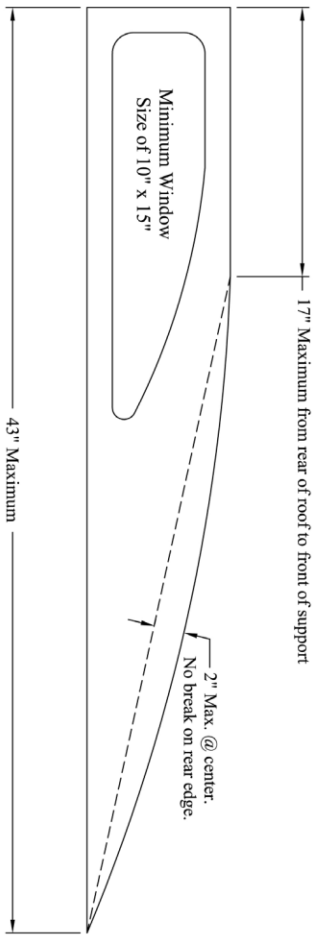

DIRT LATE MODEL,
WINDOW SIDE PANEL
& REAR ROOF SUPPORT